

Cylinder Ordering Information

This reference sheet can be used to order replacement cylinders.

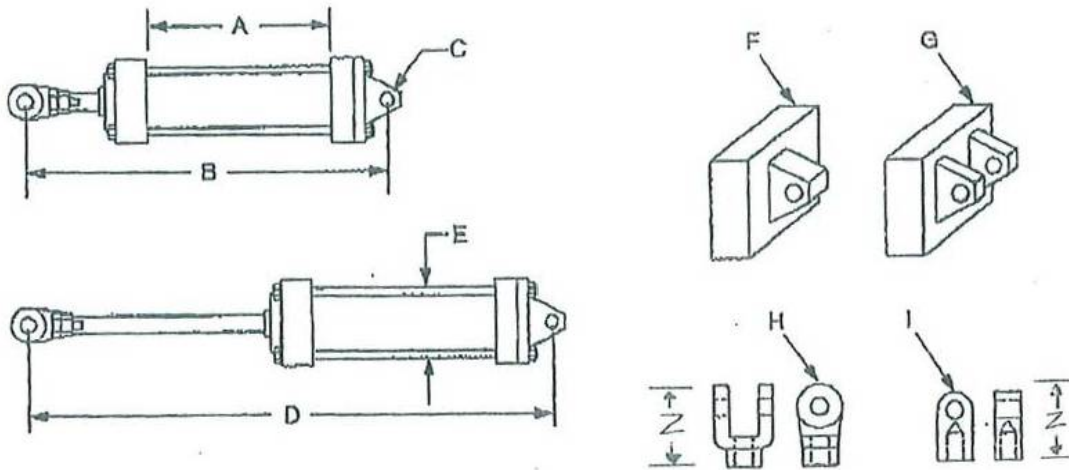

A= Cylinder Body Length

B= Cylinder Length (Retracted)-Mounting Pin
Center to Center

C= Mounting Pin Diameter
(Front & Rear)

D= Cylinder Length (Extended)- Mounting Pin
Center to Center

E= Approximate Cylinder Diameter

Z=

Cushions?

Yes

No

Choose a Mounting Bracket Style

F= Single Tang

G= Double Tang

Choose a Rod Clevis Style

H= Rod Clevis

I= Rod Eye